



Energy  
Management

---

EE0016 ↻ NOV2023

---



PATENTED



## Pre-assembled DB manifolds with integrated dynamic balancing



Efficiency, reliability, comfort: maximum  
performance in heating and cooling systems.

## Why use dynamically-balanced distribution manifolds?

An unbalanced system is essentially an inefficient system.

The DB series (Dynamic Balancing) manifolds are used in radiant heating and cooling systems.

A system with DB series manifolds can keep the flow rate balanced at all times, in all of the system's circuits.

This guarantees that the right amount of thermal energy is delivered to every part of the building, with consequent benefits in terms of energy efficiency and comfort.

### ➤ Partial load with and without flow rate balancing

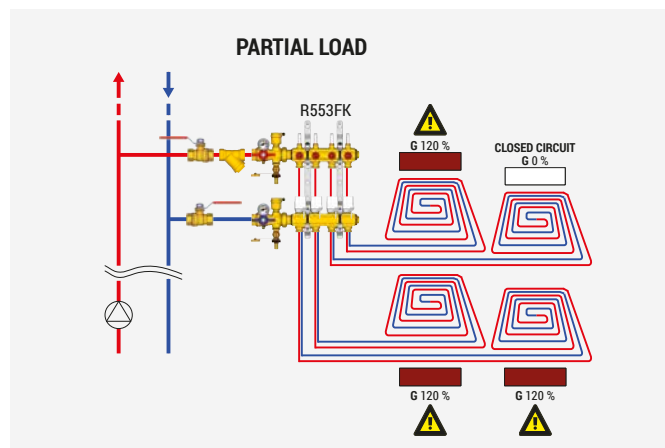

Radiant system with R553FK manifolds without flow rate balancing

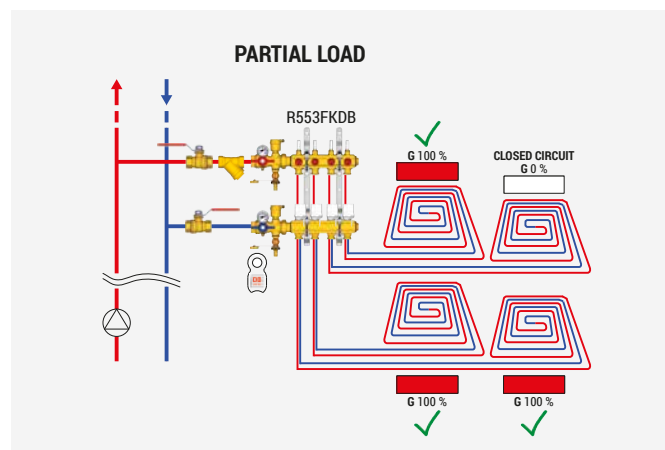

Radiant system with R553FKDB dynamically-balanced manifolds

### ➤ Main benefits

**Complete and accurate management:**  
pre-setting, continuous control and shut-off

**Simple and immediate circuit calibration,**  
especially in complex systems being upgraded

**Balanced flow rate in the individual circuits** for the highest levels of comfort and energy saving

Energy savings of up **to 25%\*** compared to systems without dynamic balancing

\* Results obtained from the research carried out by the Department of Energy at the Turin Polytechnic (scientific director Prof. Stefano Corgnati).

Examples: 12% energy saving in a single residential unit / 14%-25% energy saving in an apartment block heating plant with 8 residential units, depending on the number of apartments, with a specific occupancy profile (system always on, off for 7 hours, off for 5 hours)

The DB series distribution manifolds are equipped with a built-in cartridge that controls and limits the flow rate according to preset values.

The preset flow rate on the cartridge will not be exceeded, even when the load changes in the system due to other circuits being closed/opened or when first starting the system.

Within a minimum and maximum differential pressure range, this operation is completely independent of the differential pressure.

As the desired design flow rate can be preset directly on the cartridge using an R73P adjustment tool, complicated pressure drop and balancing calculations are no longer necessary; furthermore, commissioning times are much faster.

These characteristics are very important in new systems, and even more significant in renovations, where many of the parameters are often not known to the designer or installer.

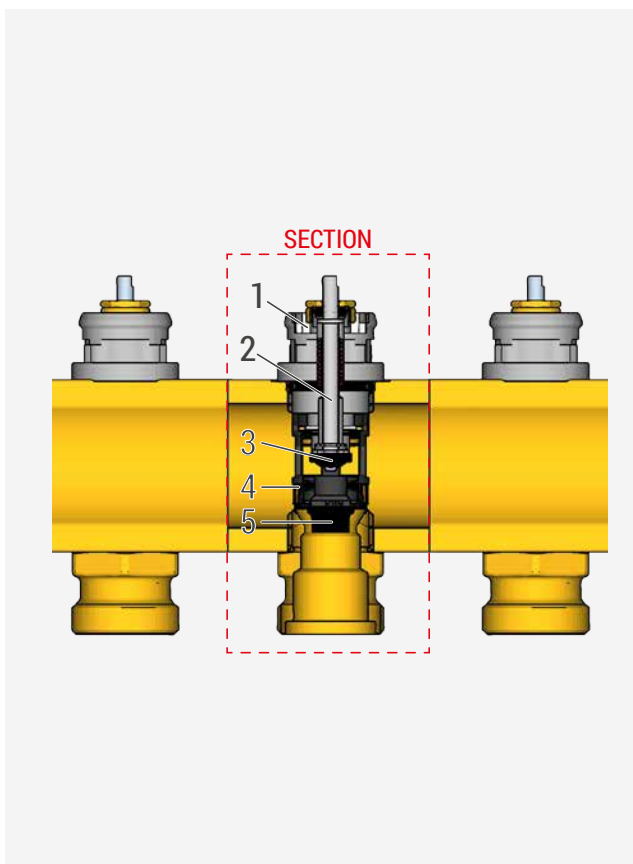

---

1 Indicator ring

---

2 Stem in stainless steel

---

3 Stopper in EPDM

---

4 Regulation separators

---

5 Balancing membrane with controlled deformation in EPDM

---

## Patented cartridge with EPDM controlled-deformation balancing membrane

If, during system operation, the flow rate starts to increase when other system circuits are closing, the cartridge membrane will reduce the opening surface area, so that the flow rate is automatically limited to the preset value. Conversely, if the flow rate starts to fall below the preset value, the cartridge membrane expands the opening surface area and the flow rate increases back to the preset value.

# Flow rate presetting

The DB manifolds keeps the flow rate constant in the individual circuits of the system, within a minimum and maximum differential pressure range, regardless of the operating conditions in the other circuits.

The manifolds, in combination with thermo-eletric actuator, can perform various functions:

## Flow rate control:

when pressure varies due to the opening or closing of some of the circuits, the cartridge membrane adjusts its opening, consequently adapting the flow rate to the preset value, even with high differential pressures; operation up to 60 kPa for Low Flow, up to 150 kPa for High Flow.

## Flow rate presetting:

the maximum design flow rate that must be kept constant can be set for each individual circuit.

## Room temperature optimisation:

the combination of a DB manifold, an thermo-eletricactuator and a room thermostat optimises temperature management in a different rooms.

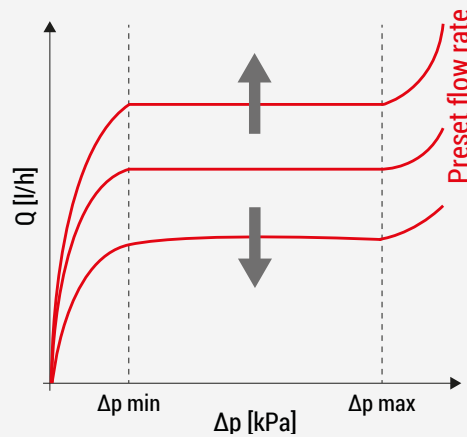

➔ **Flow rate presetting requires just 4 simple steps, using the R73P adjustment tool**

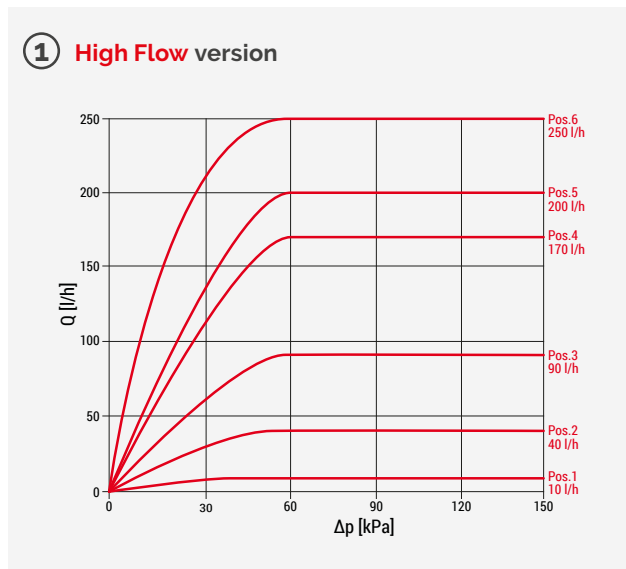
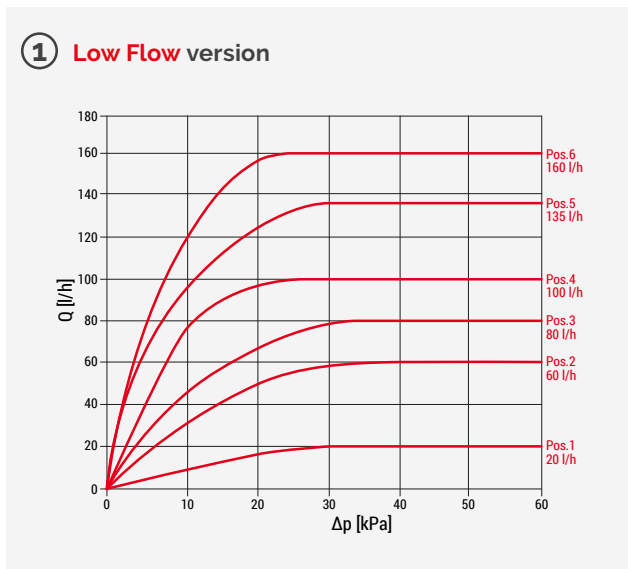

1. On the flow rate presetting diagram, identify which cartridge position corresponds to the desired flow rate.

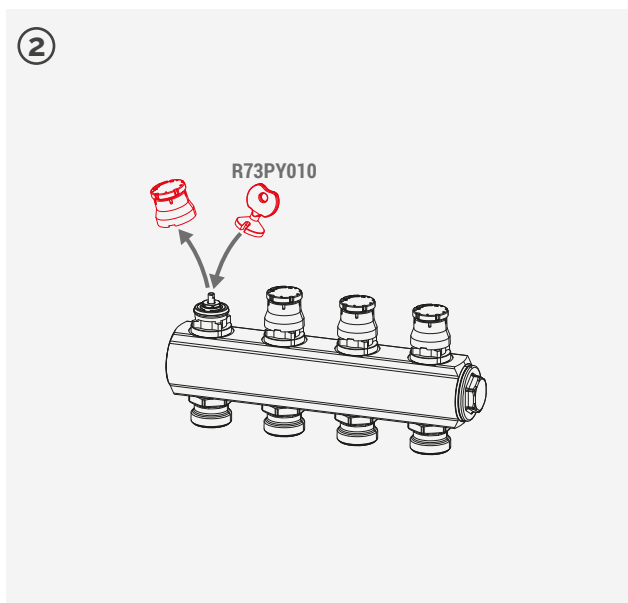

2. Remove the knob from the valve and place the adjustment tool on the cartridge.

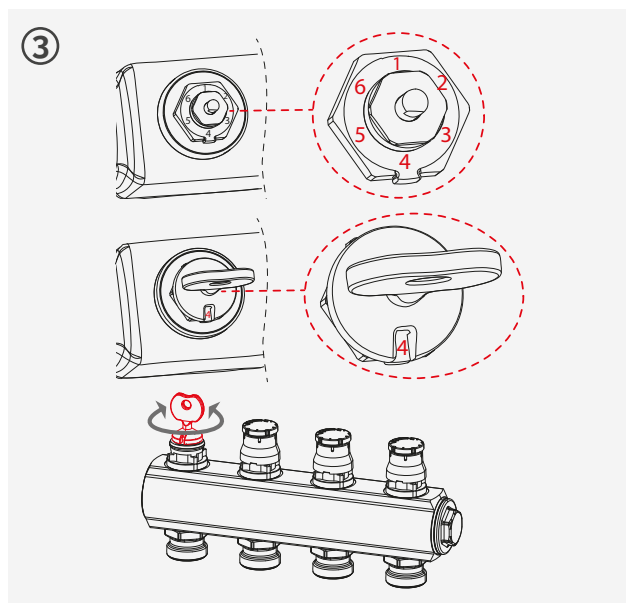

3. Turn the adjustment tool until the desired position is indicated in the tool slot.

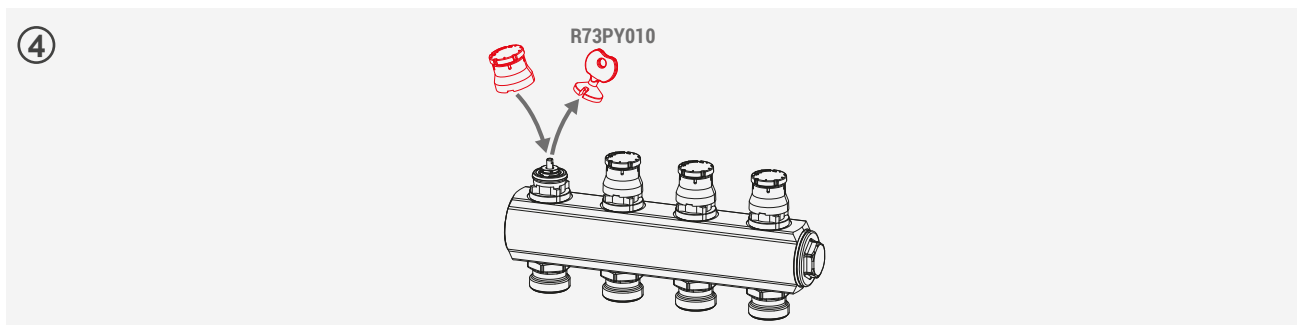

4. Remove the adjustment tool and reposition the knob or any electric thermostatic valve.

➤ The DB series range of distribution manifolds is available in three different materials



Brass R553FKDB

Technopolymer R553FPDB

Stainless steel R553FSDB

➤ Each project has its own manifold: the DB manifolds are available in the Low Flow or High Flow versions

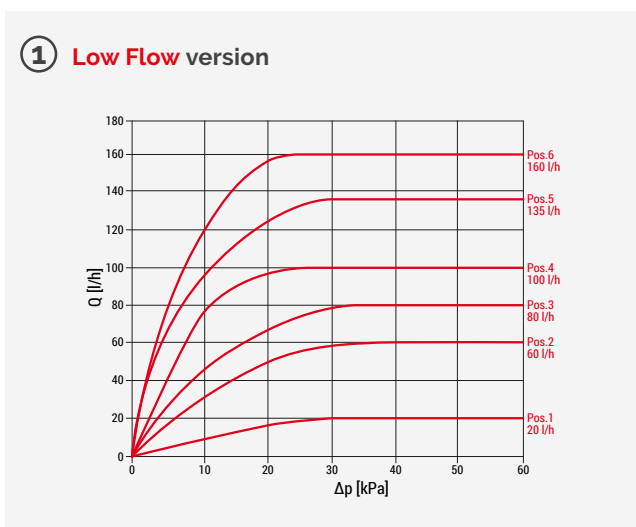

SETTING POSITION	1	2	3	4	5	6 (factory pos.)
Flow-rate - l/h	20	60	80	100	135	160
$\Delta p$ min - kPa	20	20	20	20	20	20
$\Delta p$ max - kPa				60		

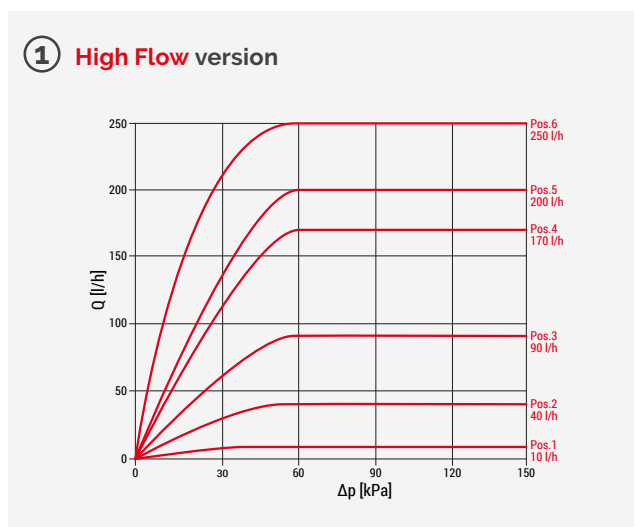

SETTING POSITION	1	2	3	4	5	6 (factory pos.)
Flow-rate - l/h	10	40	90	170	200	250
$\Delta p$ min - kPa	40	40	40	40	40	30
$\Delta p$ max - kPa				150		

Note.  $\Delta p$  min =  $\Delta p$  corresponding to a value  $\geq 80\%$  of preset flow rate.